



AD-285

MAXIMUM CAPACITY (DRY WEIGHT)		30 lb	13.6 kg	
TUMBLER DIAMETER		27-1/4"	69.22 cm	
TUMBLER DEPTH		30"	76.2 cm	
TUMBLER VOLUME		10.18 cu ft	288.27 L	
TUMBLER/DRIVE MOTOR		1/2" hp	0.373 kW	
BLOWER/FAN MOTOR		N / A		
DOOR OPENING (DIAMETER)		21-1/2"	54.61 cm	
DOOR SILL HEIGHT		26-3/8"	67 cm	
WATER CONNECTION		3/4"-11.5 NH (North America) 3/4" B.S.P.T. (Outside North America)		
DRYERS PER 20'/40' CONTAINER		14 / 30		
DRYERS PER 48'/53' TRUCK		36 / 38		
Gas	VOLTAGE AVAILABLE		120-480V 1,3ø 2,3,4w 50/60 Hz	
	APPROXIMATE NET WEIGHT		455 lb 206.4 kg	
	APPROXIMATE SHIPPING WEIGHT		500 lb 226.8 kg	
	AIRFLOW 60 Hz		375 cfm 11 cmm	
	50 Hz		313 cfm 8.85 cmm	
	HEAT INPUT		72,000 Btu/hr 18,144 kcal/hr	
	EXHAUST CONNECTION (DIAMETER)		6" 15.24 cm	
	COMPRESSED AIR CONNECTION		N / A	
	COMPRESSED AIR VOLUME		N / A	
	INLET PIPE CONNECTION		1/2" N.P.T. 1/2" B.S.P.T. (CE and Australia Only)	
Electric	VOLTAGE AVAILABLE		N / A	
	APPROXIMATE NET WEIGHT			
	APPROXIMATE SHIPPING WEIGHT			
	AIRFLOW			
	EXHAUST CONNECTION (DIAMETER)			
	COMPRESSED AIR CONNECTION			
	COMPRESSED AIR VOLUME			
	OVEN SIZE			
kW	Btu/hr	kcal/hr		
Steam	VOLTAGE AVAILABLE		N / A	
	APPROXIMATE NET WEIGHT			
	APPROXIMATE SHIPPING WEIGHT			
	AIRFLOW			
	STEAM CONSUMPTION			
	OPERATING STEAM PRESSURE			
	EXHAUST CONNECTION (DIAMETER)			
	COMPRESSED AIR CONNECTION			
	COMPRESSED AIR VOLUME			
	BOILER HORSEPOWER (NORMAL LOAD)			
	SUPPLY CONNECTION			
	RETURN CONNECTION			

Shaded areas are stated in metric equivalents

4/2/07

AD-285

DRYER NOTES:

- DUCTWORK SIZE VARIES WITH INSTALLATION CONDITIONS.
- EXHAUST STATIC PRESSURE MUST BE NO LESS THAN 0 AND MUST NOT EXCEED 0.3" (0.74 MB) WATER COLUMN

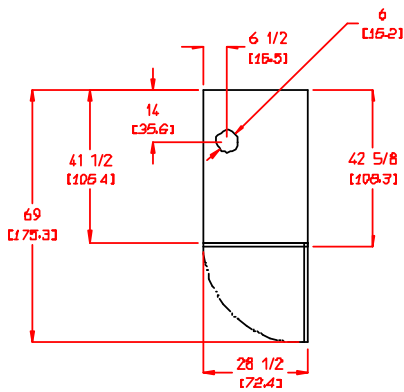

PLAN VIEW

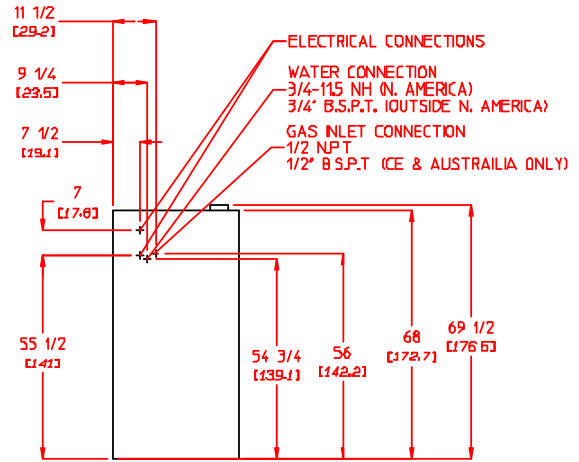

REAR VIEW

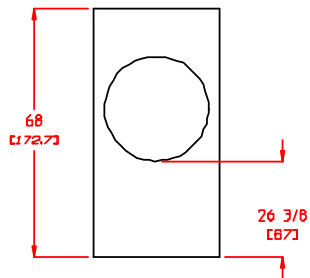

FRONT VIEW

1/26/04



88 Currant Road • Fall River, MA 02720
 Tel. 508-678-9000 • Fax 508-678-9447
 sales@amdry.com • www.amdry.com